

INSTRUCTIONS
(Fiber Optic Permit Application)

A Fiber Optic Permit application requests permission for the use of right-of-way, streets, other municipally owned property; and in some instances, existing easements which previously have been granted by the Township to public utilities for the purpose of installing overhead and/or underground cable, conduits, wires and similar equipment. ***NOTE:** Not applicable to PSE&G, Bell Atlantic or Cable Television franchise granted by the Township.

Prior to submitting an Application, you should review the Township's Fiber Optic Cable Ordinance and amendment, both of which are included in the application package.

APPLICATIONS CAN ONLY BE SUBMITTED ELECTRONICALLY ADDRESSED TO: THE TOWNSHIP OF PISCATAWAY, DIVISION OF ENGINEERING: ATTN: JESSE HARVEY, AT: JHarvey@piscatawaynj.org (C.C. JHerrera@piscatawaynj.org) AND MUST CONTAIN THE FOLLOWING:

- A. **APPLICATION FOR FIBER OPTIC CABLE INSTALLATION**
- B. **IDEMNIFICATION AGREEMENT** from owner of the Fiber Optic Cable.
- C. **FIBER OPTIC CONDUIT USE AGREEMENT**
- D. **DETAILED PLANS** with description of proposed cable location above and below ground. (Note: for below ground cable, use detectable metallic warning tape. Above ground (aerial) cable to be installed at a minimum vertical height of 15 feet above the highest point in the Right-of-Way. Identify all Utility Poles). A current infrastructure map showing applicant's proposed and existing aerial and underground fiber optic lines in the Township must be included.
- E. **CERTIFICATE OF INSURANCE** (**MUST** name the Township as additional insured for general liability in the minimum amount of \$5,000,000.00) (**by Contractor and Applicant**). The location of each installation must be indicated on each certificate.
- F. **INDEMNIFICATION /HOLD HARMLESS AGREEMENT** from the Contractor.
- G. **ANNUAL PERMIT FEES*** (in accordance with the **Fee Schedule** set forth in the attached Ordinance #20-16.) – **Must be submitted with application.**
- H. **PAYMENTS** simultaneous with the electronic submission, applicant must mail the two checks described in items I and J below to the Township of Piscataway Engineering Department, 455 Hoes Lane, Piscataway, New Jersey 08854.
Attention: **Jesse C. Harvey IV**
Senior Assistant Engineer
- I. **PROFESSIONAL REVIEW ESCROW (\$750.00 minimum).**
- J. **FIBER OPTIC PERMIT FEE (500.00 minimum).**

***NOTES:**

- 1.) Not applicable to PSE & G, Bell Atlantic or Cable Television franchise granted by the Township.
- 2.) A STREET OPENING PERMIT, STREET OPENING PERMIT FEE AND A CASH BOND ARE ALSO REQUIRED for underground lines only. The amount of the fee and bond will be furnished to you prior to approval of the Fiber Optic Permit.
- 3.) Applicant must use the exact forms prepared by the Township. No changes will be accepted.
- 4.) The Indemnification Agreement, Fiber Optic Conduit Use Agreement and Indemnification Hold Harmless Agreement must each include the typed name of each person signing and that person's title. If the applicant is a corporation then a corporate officer such as a president or vice-president must sign and that signature attested by the corporate secretary or assistant secretary. If the applicant is a limited liability company then a managing member must sign and that signature witnessed by a second person.
- 5.) An incomplete application will be subject to an additional professional escrow fee.
- 6.) A fiber optic application must be filed even if the fiber optic line is proposed to be run through an existing conduit. In such a situation a notarized agreement signed by the owner of the existing conduit must be furnished for the application to be complete.
- 7.) If applicant or contractor is a corporation, all documents must be signed by the corporate president or vice-president and attested to by the corporate secretary or assistant secretary. If the applicant or contractor is a limited liability company then all documents must be signed by the managing member of the LLC, and the signature witnessed.

PRIOR TO THE START OF CONSTRUCTION THE CONTRACTOR SHALL:

Notify at least 24 hours prior to construction the Engineer's Office and Piscataway Police for traffic control. (Traffic control to conform with "Standards for Work Zone – Traffic Control" Part VI of the Manual of Traffic Control Devices Latest Edition).

DURING CONSTRUCTION THE CONTRACTOR SHALL:

Keep construction site clean and in a safe condition for pedestrian and vehicular traffic.

Advise Township Engineer's Office at least 24 hours prior to backfill operations.

AFTER CONSTRUCTION THE CONTRACTOR SHALL:

Notify the Township Engineer's Office and arrange for a final inspection of the project.

ADDITIONAL REQUIREMENTS:

At least 48 hours prior to the commencement of any underground construction work; the Contractor shall deliver to every affected property owner a notice of commencement of

underground construction work.

The Contractor shall protect inlets adjacent to the course of the underground construction work using hay bale barriers and/or filter fabric.

The Contractor shall repair all damage to driveways caused by the Contractor's underground construction work, including Belgian Block, wood ties and similar edging materials. In repairing driveways, the Contractor shall match existing material. Repairs or replacements shall contain a minimum 4" of 3/4" stone and 2" of bituminous concrete mix 1-5, or 6" of 4500 p.s.i. concrete. The Contractor shall replace all driveway aprons that are cut by the Contractor in connection with its underground construction work.

The Contractor shall comply with all of the Township's applicable construction details which are available at the Engineering Office. The Contractor shall replace any grass that dies as a result of the Contractor's underground construction work provided, however, that the grass has not died as a result of the property owner's (homeowner) failure to adequately water it.

The Contractor shall replace any trees that die within two (2) years as a result of the Contractor's underground construction work. All trenching shall take place as far away as possible from street trees, while still remaining in the public right of way.

The Contractor shall limit potential damage to Township trees by taking all necessary precautions. Damaged trees shall be reviewed by contractor with the Township Landscape Architect and any repairs required by the Landscape Architect shall be performed by the Contractor.

Both the Township and the Contractor shall maintain a list of the name and address of each person making a complaint regarding the construction work, the date of the complaint, and the nature of the complaint. The Township and the Contractor shall periodically exchange such lists with each other.

Nothing contained herein shall be construed as a waiver of any State, Federal, County or Local Ordinance, regulation or requirement.

PERMIT # _____

APPLICATION CHECKLIST

DATE: _____

APPLICANT: _____

ADDRESS: _____

CONTACT PERSON

NAME: _____

ADDRESS: _____

PHONE No.: _____

E-MAIL: _____

REQUIRED ITEM

STATUS

	STATUS	
	SUBMITTED	PENDING
APPLICATION		
FIBER OPTIC PERMIT FEE (MIN. \$500.00)		
STREET OPENING PERMIT FEE		
INDEMNIFICATION AGREEMENT (CONTRACTOR'S AND OWNER'S)		
FIBER OPTIC CONDUIT USE AGREEMENT		
DETAILED PLANS AND INFRASTRUCTURE MAP (MIN. 24"x36")		
CERTIFICATE OF INSURANCE		
PROFESSIONAL ESCROW (MIN. \$750.00)		
AGREEMENT SIGNED AND NOTARIZED BY OWNER OF EXISTING CONDUIT (IF APPLICABLE)		

***NOTE:**

DO NOT SUBMIT UNTIL ALL ITEMS ON THIS CHECKLIST ARE INCLUDED. INCOMPLETE SUBMISSIONS WILL BE SUBJECT TO ADDITIONAL FEES. YOU MUST INCLUDE YOUR PHONE NUMBER AND E-MAIL ADDRESS. APPLICATIONS WILL NOT BE APPROVED UNTIL A COMPLETE SUBMISSION IS RECEIVED.



APPLICATION
For
FIBER OPTIC CABLE INSTALLATION

Tel. # 732 – 562-6560
Fax # 732 – 529-2525

THE CONTRACTOR MUST BE IN POSSESSION OF A PERMIT BEFORE STARTING CONSTRUCTION:

APPLICANT'S NAME: _____

APPLICANT'S ADDRESS: _____

APPLICANT'S E-MAIL: _____

CONTRACTOR'S NAME: _____

CONTRACTOR'S ADDRESS: _____

TELEPHONE NO: _____ EMERGENCY NO. _____

FAX NO. _____

FEDERAL I.D. # _____

FOR LOCATION OF OPENING(S) - ATTACH PLANS

Title of Plans: _____

Prepared by: _____

Dated: _____ 20 _____

Last Revision Date: _____ 20 _____

No. of Pages: _____

Special Conditions (by Applicant) _____

WORK START DATE _____ WORK FINISH DATE _____

Are you the only user of the fiber optic cable _____ YES _____ NO

If NO, who will be additional user _____

CONSTRUCTION STANDARDS

The Contractor shall adhere to the Town of Piscataway, Utility and Landscape standards, (available at the Engineer's Office) for the repair, restoration and replacement of structures, pavement, trench, etc. disturbed during construction.

If the contractor willfully falsifies any of the above information or does not adhere to the aforesaid conditions, the Town reserves the right to revoke this permit and/or levy a fine against the Contractor as permitted by Town Ordinance.

Contractor's Printed Name

Contractor's Signature

Date

FOR TOWNSHIP USE ONLY

Permit No. _____

Application Approved by _____

Inspected for Backfill by _____

Inspected for Temporary Backfill _____ Date: _____

Inspected for Final Approval by _____ Date: _____

Inspected for Final Trench Repair _____

Notify Finance/Annual Fee _____ Amount \$ _____

SPECIAL REMARKS BY ENGINEER _____

DEFENSE, INDEMNIFICATION AND HOLD HARMLESS AGREEMENT

_____ and _____

(hereinafter the “Applicant” and “Contractor”, respectively), in conjunction of the TOWNSHIP OF PISCATAWAY (hereinafter the “Township”) granting approval for the installation and operation of fiber optic cable(s) within the public right-of-way and properties owned by the Township within and near _____, as designated and shown on the plans entitled _____

(which plans are incorporated as a part thereof), agree as follows:

1. Applicant and Contractor shall jointly, severally and in the alternative defend, indemnify and hold harmless the Township, its Mayor, Councilpersons, officers, agents and employees, from and all losses and all claims, demands, payments, suits, actions, recoveries, judgments, counsel fees, costs and disbursements of any nature and description, brought or recovered against it by reason of any act or omission, claim or damage arising out of the installation, maintenance, or use of the fiber optic cable and related equipment and accessories.
2. Upon completion of the work related to the aforesaid purposes, Applicant and Contractor shall cause all vehicles, equipment, tools and implements used in such work, and all materials not incorporated therein, to be promptly removed from said lands and shall cause said lands to be left in the same condition as before the work was commenced .

ATTEST (If a Corporation) or
WITNESS

APPLICANT: _____
BY: _____
TITLE: _____

CONTRACTOR: _____
BY: _____
TITLE: _____

FIBER OPTIC OR OTHER CABLE CONDUIT USE AGREEMENT

THIS FIBER OPTIC OR OTHER CABLE CONDUIT USE AGREEMENT (the "Agreement") is made as of _____, 20_____, between _____, which has a place of business at _____ ("Grantor") and Township of Piscataway, having a place of business at, 455 Hoes Lane, Piscataway, NJ 08854 ("Grantee").

WHEREAS, Grantor has or intends to acquire easements, conduit rights, pole attachment and license agreements to construct, install, operate, maintain, modify, replace or remove a redundant communications transmission system in Piscataway, NJ, (the "Route")(See Attachment: Appendix A); and

WHEREAS, Grantor has or intends to install, construct, operate and maintain an optical fiber communication transmission system on utility poles or within conduit systems located on the Route (collectively, "Grantor's Fiber and Conduit System"); and

WHEREAS, Grantor is required by state law to obtain municipal consent to locate Grantor's Fiber and Conduit System within the public right of way along the Route; and

WHEREAS, Grantee has requested as a condition to grant municipal consent an option to use six (6) strands of each optical fiber cable installed along the Route; and

WHEREAS, Grantor agrees to grant such option and use subject to the terms and conditions set forth in this Agreement.

NOW, THEREFORE, it is hereby agreed as follows:

1. Grantor grants to Grantee and Grantee accepts from Grantor an exclusive and infeasible license solely for authorized use of Grantee's fiber optic facilities (hereinafter defined) in Grantor's fiber and conduit system (the "License"), as provided in this Agreement.

2. Grantee's "fiber optic facilities" means six (6) strands (hereinafter defined) of each fiber optic cable installed originally in each fiber optic cable over-lashed in the future, as designated by Grantor. Grantee's fiber optic facilities are dedicated exclusively to Grantee, and Grantor may not share or otherwise make available such strands for any other customer or for any other purpose. The fiber optic facilities are provided to Grantee exclusively for Grantee's non-commercial internal governmental use and Grantee shall not allow any third party to use such fiber optic facilities. "Strands" means individual fiber optic strands within the Grantee's fiber optic facilities.

3. Grantee shall not be obligated to make any payment or provide any other consideration to Grantor for the License, other than Grantee furnishing its approval of a conduit within the public right-of-way and/or public property for the purpose of carrying Grantor's fiber optic or other cables.

4. The term of the License shall commence on the acceptance date defined below, and shall continue for the duration of Grantor's utilization of the municipal right-of-way and/or

municipal property for its fiber and conduit system.

5. Grantor shall furnish and install Grantee's fiber optic facilities along the Route that Grantor constructs pursuant to its approval from Grantee, and shall be constructed substantially and in all material respects in accordance with industry standards and specifications. Grantor shall pay for the cost of the fiber optic facilities and the cost of installation at its own cost and expense.

6. Grantor shall test all Grantee's fiber optic facilities upon completion of installation to verify that Grantee's fiber optic facilities are installed and operational in accordance with standard fiber optic specifications. When Grantor has determined that the results of the testing with respect to the entire span show that Grantee's fiber optic facilities are installed and operating, Grantor shall properly notify Grantee in writing and the date of such notice shall constitute the acceptance date.

7. Grantor shall maintain Grantee's fiber optic facilities at Grantor's sole cost and expense. Grantee shall cooperate with and assist Grantor, as may be reasonably required, in performing said maintenance.

8. Notwithstanding anything to the contrary contained herein, Grantee shall solely be responsible, at Grantee's sole cost and expense, for the construction, installation, operation, maintenance, repair and any other activity engaged by or on behalf of Grantee relating to all light communications transmission equipment and other terminal equipment and facilities required in connection with the use, electronics or signals of Grantee's Fiber Optic Facilities. Grantor shall not be responsible for providing any equipment as part of this Agreement.

9. Grantor shall be responsible for all necessary splicing.

10. Grantor shall be responsible for obtaining and maintaining from the appropriate public or private authority any pole attachment agreements, franchises, licenses, state, local or right-of-way permits or other authorizations required to enter upon the property where Grantor's Fiber and Conduit System is located and to operate and maintain Grantee's Fiber Optic Facilities in Grantor's Fiber and Conduit System. Grantee will not engage in any activity which affects Grantor's right-of-way interests without the written permission of Grantor.

11. Grantee, at its sole cost and expense, shall (i) use Grantee's Fiber Optic Facilities and (ii) conduct all work in or around Grantor's Fiber and Conduit System in a safe condition and in a manner reasonably acceptable to Grantor, so as not to physically, electronically or inductively conflict or interfere or otherwise adversely affect Grantor's Fiber and Conduit System or the facilities placed therein by Grantor, or other authorized grantees of the Fiber Optic Facilities.

12. Grantor shall designate the particular strands of each fiber optic cable that will constitute Grantee's Fiber Optic Facilities, as well as the location and manner in which said strands will enter and exit Grantor's Fiber and Conduit System.

13. Each party will reimburse the other for the full actual loss, damage or destruction of the other's tangible property, to the extent caused by its own gross negligence or willful and wanton misconduct.

14. Each party shall both obtain and maintain insurance issued by one or more reputable insurance carriers licensed to insure property in New Jersey which protects the parties and each of them from and against all claims, demands, causes of action, judgments, costs, including attorney's fees, expenses and liabilities of insurable kind and nature which may arise or result directly or indirectly from or by reason of such loss, injury or damage that in any way arises from or is related to this Agreement or activities undertaken pursuant to this Agreement.

15. Grantor makes no warranty regarding the materials and services provided under this Agreement, and makes not warranties, express or implied, including any implied warranties of merchantability or fitness for a particular purpose.

16. No course of dealing, course of performance or failure of either party strictly to enforce any term, right or condition of this Agreement shall be construed as a waiver of any term, right or condition.

17. The construction, interpretation or performance of this Agreement shall be governed by the laws of the State of New Jersey, without regard for its conflict of laws or choice of laws provisions thereof.

IN WITNESS WHEREOF, the parties hereto have caused this Agreement to be signed by their respective representatives.

ATTEST:

TOWNSHIP OF PISCATAWAY, Grantee

MELISSA SEADER, Township Clerk

By: _____
BRIAN C. WAHLER, Mayor

ATTEST:

GRANTOR - IF A CORPORATION

Secretary or Assistant Secretary

By: _____
President or Vice-President

Print Name: _____

Print Name: _____

WITNESS:

GRANTOR – IF A LIMITED LIABILITY COMPANY

BY: _____
Managing Member

Print Name: _____

Print Name: _____



CERTIFICATE OF LIABILITY INSURANCE

DATE(MM/DD/YYYY)

THIS CERTIFICATE IS ISSUED AS A MATTER OF INFORMATION ONLY AND CONFERS NO RIGHTS UPON THE CERTIFICATE HOLDER. THIS CERTIFICATE DOES NOT AFFIRMATIVELY OR NEGATIVELY AMEND, EXTEND OR ALTER THE COVERAGE AFFORDED BY THE POLICIES BELOW. THIS CERTIFICATE OF INSURANCE DOES NOT CONSTITUTE A CONTRACT BETWEEN THE ISSUING INSURER(S), AUTHORIZED REPRESENTATIVE OR PRODUCER, AND THE CERTIFICATE HOLDER.

IMPORTANT: If the certificate holder is an ADDITIONAL INSURED, the policy(ies) must be endorsed. If SUBROGATION IS WAIVED, subject to the terms and conditions of the policy, certain policies may require an endorsement. A statement on this certificate does not confer rights to the certificate holder in lieu of such endorsement(s).

PRODUCER	CONTACT NAME:		FAX (A/C. No.):	
	PHONE (A/C. Ext):			
MAIL ADDRESS:				
INSURER(S) AFFORDING COVERAGE				NAIC #
INSURED	INSURER A:	NAME OF INSURANCE CARRIER		
	INSURER B:			
	INSURER C:			
	INSURER D:			
	INSURER E:			
	INSURER F:			

COVERAGES **CERTIFICATE NUMBER: 570048379367** **REVISION NUMBER:**

THIS IS TO CERTIFY THAT THE POLICIES OF INSURANCE LISTED BELOW HAVE BEEN ISSUED TO THE INSURED NAMED ABOVE FOR THE POLICY PERIOD INDICATED. NOTWITHSTANDING ANY REQUIREMENT, TERM OR CONDITION OF ANY CONTRACT OR OTHER DOCUMENT WITH RESPECT TO WHICH THIS CERTIFICATE MAY BE ISSUED OR MAY PERTAIN, THE INSURANCE AFFORDED BY THE POLICIES DESCRIBED HEREIN IS SUBJECT TO ALL THE TERMS, EXCLUSIONS AND CONDITIONS OF SUCH POLICIES. LIMITS SHOWN MAY HAVE BEEN REDUCED BY PAID CLAIMS. **Limits shown are as requested**

INSR LTR	TYPE OF INSURANCE	ADDL INSR	SUBR WVD	POLICY NUMBER	POLICY EFF (MM/DD/YYYY)	POLICY EXP (MM/DD/YYYY)	LIMITS	
A	GENERAL LIABILITY		Y	711-01-29-76-0001	12/12/2012	12/12/2013	EACH OCCURRENCE	\$1,000,000
	<input checked="" type="checkbox"/> COMMERCIAL GENERAL LIABILITY						DAMAGE TO RENTED PREMISES (Ea occurrence)	\$1,000,000
	<input type="checkbox"/> CLAIMS-MADE <input checked="" type="checkbox"/> OCCUR						MED EXP (Any one person)	\$10,000
	GEN'L AGGREGATE LIMIT APPLIES PER:						PERSONAL & ADV INJURY	\$1,000,000
	<input type="checkbox"/> POLICY <input type="checkbox"/> PRO-JECT <input checked="" type="checkbox"/> LOC						GENERAL AGGREGATE	\$2,000,000
							PRODUCTS - COMP/OP AGG	\$2,000,000
A	AUTOMOBILE LIABILITY			711-01-29-76-0001	12/12/2012	12/12/2013	COMBINED SINGLE LIMIT (Ea accident)	\$1,000,000
A	<input checked="" type="checkbox"/> ANY AUTO			390-00-12-16-0001	12/12/2012	12/12/2013	BODILY INJURY (Per person)	
	<input type="checkbox"/> ALL OWNED AUTOS						BODILY INJURY (Per accident)	
	<input checked="" type="checkbox"/> HIRED AUTOS						PROPERTY DAMAGE (Per accident)	
	<input type="checkbox"/> SCHEDULED AUTOS							
	<input type="checkbox"/> NON-OWNED AUTOS							
A	<input checked="" type="checkbox"/> UMBRELLA LIAB			711-01-29-76-0001	12/12/2012	12/12/2013	EACH OCCURRENCE	\$5,000,000
	<input type="checkbox"/> EXCESS LIAB						AGGREGATE	\$5,000,000
	<input type="checkbox"/> CLAIMS-MADE							
	<input type="checkbox"/> DED <input type="checkbox"/> RETENTION							
A	WORKERS COMPENSATION AND EMPLOYERS' LIABILITY			4060382450001	12/12/2012	12/12/2013	<input checked="" type="checkbox"/> WC STATUTORY LIMITS	<input type="checkbox"/> OTHER
	ANY PROPRIETOR / PARTNER / EXECUTIVE OFFICER/MEMBER EXCLUDED? (Mandatory in NH)		Y/N				E.L. EACH ACCIDENT	\$1,000,000
	If yes, describe under DESCRIPTION OF OPERATIONS below		N	N/A			E.L. DISEASE-EA EMPLOYEE	\$1,000,000
							E.L. DISEASE-POLICY LIMIT	\$1,000,000

DESCRIPTION OF OPERATIONS / LOCATIONS / VEHICLES (Attach ACORD 101, Additional Remarks Schedule, if more space is required)

THE TOWNSHIP OF PISCATAWAY AS ADDITIONAL INSURED
(NAME AND PROJECT LOCATION)

CERTIFICATE HOLDER**CANCELLATION**

Township of Piscataway
Attn: Engineering
455 Hoes Lane
Piscataway NJ 08854 USA

SHOULD ANY OF THE ABOVE DESCRIBED POLICIES BE CANCELLED BEFORE THE EXPIRATION DATE THEREOF, NOTICE WILL BE DELIVERED IN ACCORDANCE WITH THE POLICY PROVISIONS.

AUTHORIZED REPRESENTATIVE

Ann Risk Services Northeast Inc.

Holder Identifier :

Certificate No : 570048379367

PIPE DIAMETER	TRENCH WIDTH
4"	2'-0"
6"	2'-0"
8"	2'-6"
10"	3'-0"
12"	3'-0"
15"	3'-6"
18"	3'-6"
21"	4'-0"
24"	4'-0"
27"	4'-0"
30"	4'-0"
33"	4'-6"
36"	4'-6"
42"	5'-6"
48"	6'-0"
54"	6'-0"

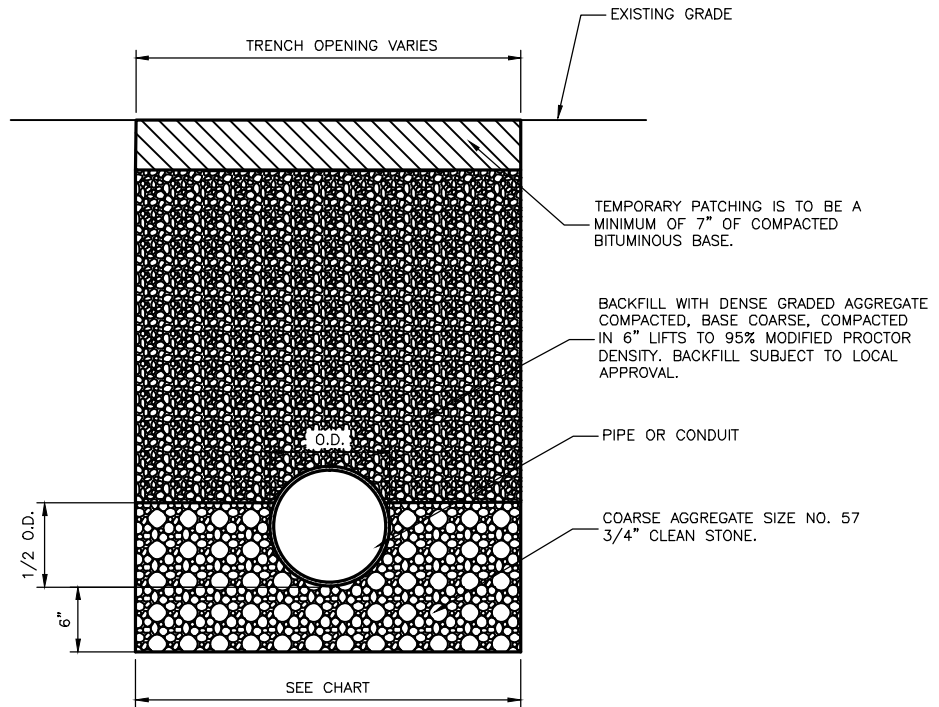

NOTES:

1. THIS DETAIL REPRESENTS THE TOWNSHIP'S MINIMUM REQUIREMENTS FOR PIPE BEDDING CONDITIONS ENCOUNTERED IN THE FIELD.
2. PIPE BEDDING TO BE DESIGNED BY CONTRACTOR AND REVIEWED BY TOWNSHIP ENGINEER. MINIMUM ORDINARY BEDDING SHALL BE CLASS "C", OR AS RECOMMENDED BY MANUFACTURER.
3. ALL MATERIALS AND CONSTRUCTION METHODS SHALL BE IN ACCORDANCE WITH NJDOT STANDARD SPECIFICATIONS, 2007 EDITION, AS AMENDED.
4. BACKFILL OPERATIONS MUST BE WITNESSED BY THE TOWNSHIP ENGINEER OR HIS REPRESENTATIVE FAILURE TO NOTIFY. THE ENGINEER 24 HRS. PRIOR TO BACKFILLING MAY RESULT IN REMOVAL AND REPLACEMENT OF THE MATERIAL.
5. PERMANENT PAVEMENT REPLACEMENT SHALL BE COMPLETED WITHIN A PERIOD OF SIX (6) MONTHS FROM THE DATE OF TEMPORARY PATCHING UNLESS THE TOWNSHIP ENGINEER SHALL DESIGNATE A DIFFERENT PERIOD OF TIME. DURING THE WINTER SEASON, AS DETERMINED BY THE TOWNSHIP ENGINEER, THE PERMANENT PAVEMENT REPLACEMENT WILL BE DEFERRED UNTIL WEATHER PERMITS.
6. TEMPORARY PAVEMENT SHALL BE PLACED AT A MINIMUM THICKNESS OF 7 INCHES. IT SHALL BE THE RESPONSIBILITY OF THE PERMITTED TO MAINTAIN SUCH TEMPORARY PAVEMENT PATCHING AND BACKFILLING TO THE EXISTING GRADE BY THE ADDITION OF BITUMINOUS ASPHALT AS REQUIRED. UNTIL PERMANENT PAVEMENT REPAIRS ARE COMPLETED BY THE CONTRACTOR. THE CONTRACTOR MUST RESPOND WITHIN 24 HOURS UPON NOTIFICATION OF THE FAILURE OF PATCH.

TOWNSHIP OF PISCATAWAY
DIVISION OF ENGINEERING
TEMPORARY PAVEMENT PATCHING

PIPE DIAMETER	TRENCH WIDTH
4"	2'-0"
6"	2'-0"
8"	2'-6"
10"	3'-0"
12"	3'-0"
15"	3'-6"
18"	3'-6"
21"	4'-0"
24"	4'-0"
27"	4'-0"
30"	4'-0"
33"	4'-6"
36"	4'-6"
42"	5'-6"
48"	6'-0"
54"	6'-0"

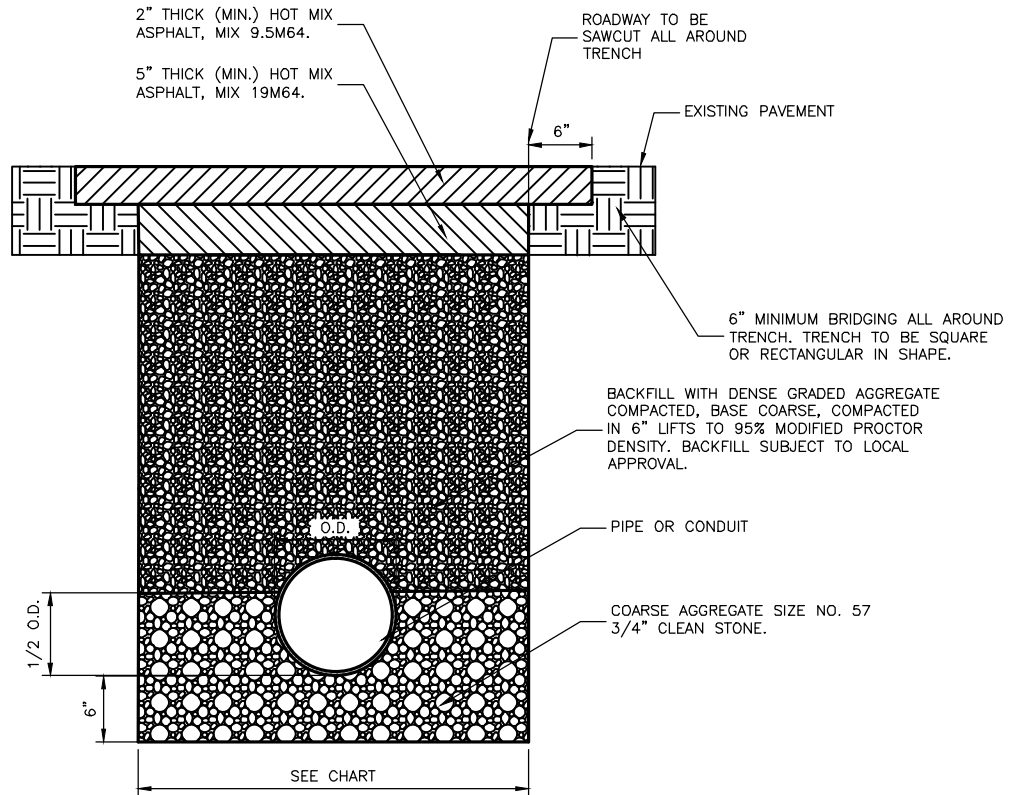

NOTES:

1. THIS DETAIL REPRESENTS THE TOWNSHIP'S MINIMUM REQUIREMENTS FOR PIPE BEDDING CONDITIONS ENCOUNTERED IN THE FIELD
2. PIPE BEDDING TO BE DESIGNED BY CONTRACTOR AND REVIEWED BY TOWNSHIP ENGINEER. MINIMUM ORDINARY BEDDING SHALL BE CLASS "C", OR AS RECOMMENDED BY MANUFACTURER.
3. ALL MATERIALS AND CONSTRUCTION METHODS SHALL BE IN ACCORDANCE WITH NJDOT STANDARD SPECIFICATIONS, 2007 EDITION, AS AMENDED.

WHEN IN THE OPINION OF THE TOWNSHIP ENGINEER, SETTLEMENT IN THE PAVEMENT OPENING HAS CEASED, PERMISSION SHALL BE GRANTED FOR PERMANENT PAVEMENT REPAIR. PERMANENT PAVEMENT REPAIR SHALL INCLUDE, BUT NOT NECESSARILY BE LIMITED TO:

- A.) SAW CUT 6" OUTSIDE OF EXISTING OPENING EDGE.
- B.) CAREFUL REMOVAL OF 2" OF EXISTING MATERIAL
- C.) THOROUGH COMPACTION OF ANY STONE SUB BASE WHICH MAY HAVE BEEN DISTURBED
- D.) INSTALLATION OF MINIMUM OF 7" OF BITUMINOUS MATERIAL AS SHOWN ABOVE.

TOWNSHIP OF PISCATAWAY
DIVISION OF ENGINEERING
PERMANENT PAVEMENT REPAIR

PIPE DIAMETER	TRENCH WIDTH
4"	2'-0"
6"	2'-0"
8"	2'-6"
10"	3'-0"
12"	3'-0"
15"	3'-6"
18"	3'-6"
21"	4'-0"
24"	4'-0"
27"	4'-0"
30"	4'-0"
33"	4'-6"
36"	4'-6"
42"	5'-6"
48"	6'-0"
54"	6'-0"

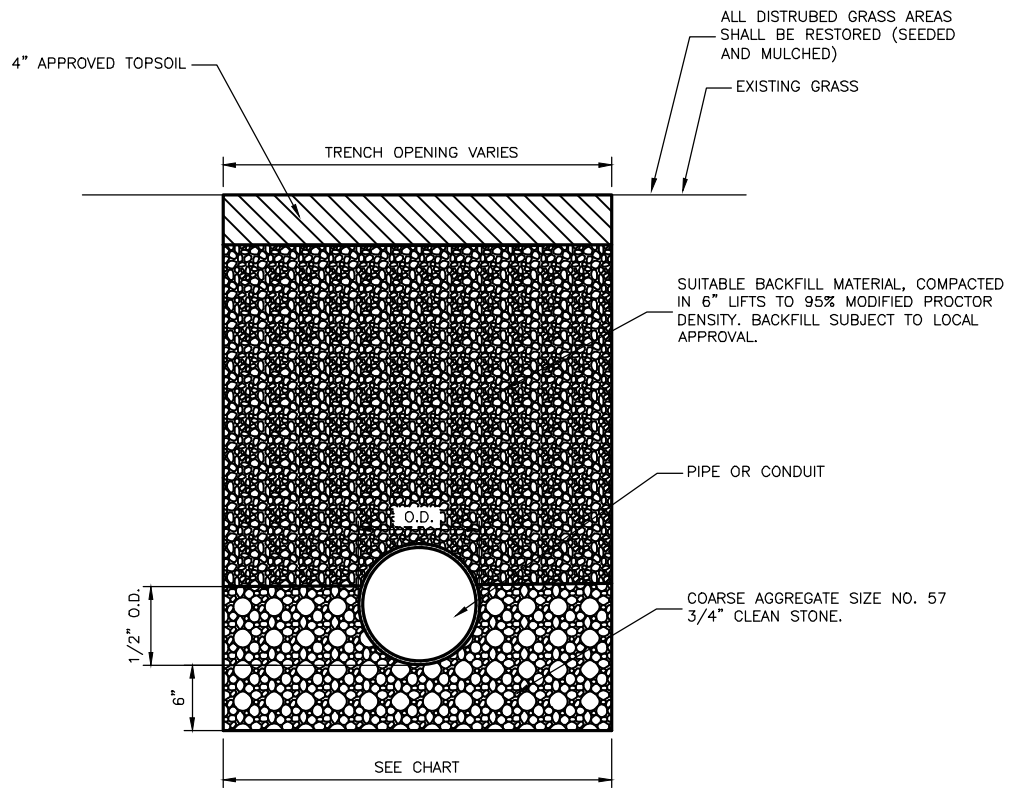

NOTES:

1. GRADE EXISTING SUBSOIL TO 4" BELOW FISHED GRADE.
2. PLACE 4" OF TOPSOIL OVER SUBSOIL (TOPSOIL MUST BE ACCEPTABLE TO TOWNSHIP ENGINEER)
3. LIME SOIL WITH PULVERIZED LIMESTONE (APPLIED AT A RATE OF 90 LBS. PER 1,000 S.F.)
4. FERTILIZE THE AREA WITH A 1-2-1 RATIO OF FERTILIZED CONTAINING A MINIMUM OF 5 PERCENT NITROGEN 10 PERCENT AVAILABLE PHOSPHORIC ACID AND 5 PERCENT SOLUBLE POTASH. (APPLIED AT A RATE OF 11 LBS. PER 1,000 S.F. FOR 10-20-10
5. PREPARE SEEDBED BY WORKING LIME AND FERTILIZED INTO THE TOP 1/3 OF TOPSOIL. FIRM ENTIRE SEEDBED.
6. APPLY APPROVED SEED UNIFORMLY OVER ENTIRE AREA (APPLIED AT A RATE OF 1.5 LBS. PER 1,000 S.F.) SEED IS TO CONSIST OF A 60% MIX OF RED FESCUE (CREEPING OR CHEWING) AND 40% PERENNIAL RYEGRASS (MANHATTAN) OR APPROVED EQUAL.
7. INCORPORATE SEED INTO TOP 1/4 - 1/2" OF TOPSOIL BY RAKING.
8. EVENLY DISTRIBUTE APPROVED STRAW MULCH (APPLIED AT A RATE 70-90 LBS. PER 1,000 S.F.)

TOWNSHIP OF PISCATAWAY
DIVISION OF ENGINEERING
TYPICAL TRENCH REPAIR
GRASSED AREA

JOINTS TO BE MAX 1/2" WIDE AND POINTED, WITH 1:2 MIX CEMENT MORTAR. JOINTS TO BE CLEANED AND DAMP PRIOR TO POINTING

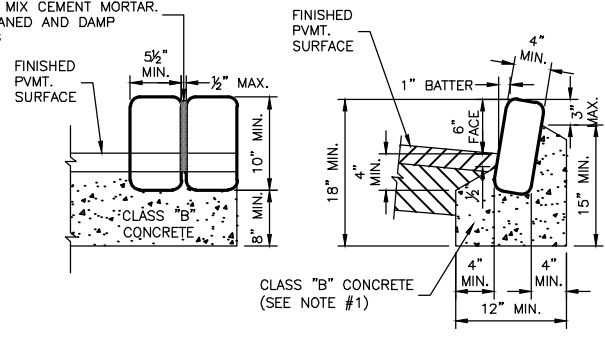

GRANITE BLOCK CURB NOTES:

1. CONCRETE TO TEST 4500 PSI MINIMUM ON 28 DAY COMPRESSIVE TEST.
2. ALL CONCRETE IS TO BE PROPERLY CURED USING A CURING COMPOUND, SALT HAY, BURLAP OR OTHER METHODS ACCEPTABLE TO THE TOWNSHIP ENGINEER.
3. CONCRETE SLUMP TO BE 3" (+-1"), OR AS DIRECTED BY THE TOWNSHIP ENGINEER.
4. CONTRACTORS TO NOTIFY TOWNSHIP ENGINEER 24 HOURS PRIOR TO POURING.

GRANITE BLOCK CURB
N.T.S.

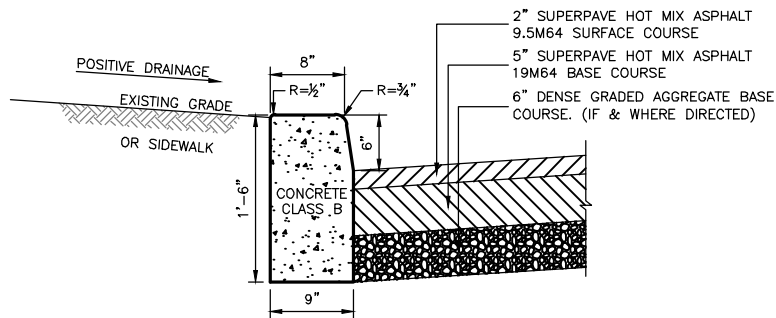

NOTES:

1. TRANSVERSE JOINTS 1/2" WIDE SHALL BE INSTALLED IN THE CURB 10'-0" APART AND SHALL BE FILLED WITH PREFORMED BITUMINOUS-IMPREGNATED FIBER JOINT FILLER COMPLYING WITH THE REQUIREMENTS OF A.A.S.H.T.O. SPEC. M-213, RECESSED 1/4" IN FROM FRONT FACE AND TOP OF CURB. EXPANSION JOINTS THROUGH AND ADJACENT TO THE CURB SHALL BE INCLUDED IN THE UNIT PRICE BID FOR CURB. DISTURBANCE AND SUBSEQUENT RESTORATION OF THE AREA BEHIND THE CURB SHALL BE LIMITED TO A MAXIMUM OF 2 FEET. PAYMENT FOR ANY PAVEMENT RESTORATION ASSOCIATED WITH CURB CONSTRUCTION SHALL BE INCLUDED IN THE BID ITEM 8"x9"x18" CONCRETE VERTICAL CURB.
2. EXPANSION JOINTS SHALL ALSO BE INSTALLED WHERE THE CURB IS ADJACENT TO SIDEWALKS AND CATCH BASINS.
3. CURB AT DRIVEWAYS AND ENTRANCES SHALL BE DEPRESSED SO THAT THE TOP OF THE CONCRETE IS 2 INCHES ABOVE THE ADJACENT PAVEMENT.
4. CONCRETE SHALL BE AIR ENTRAINED 4500 P.S.I. AT 28 DAY TEST. CONCRETE SHALL BE CURED WITH A COLORLESS CURING COMPOUND, AND FOLLOW ALL GUIDELINES AS SPECIFIED IN NEW JERSEY STATE HIGHWAY STANDARD SPECIFICATIONS, SECTION 903, FOR CONCRETE.

8"X9"X18" CONCRETE VERTICAL CURB
N.T.S.

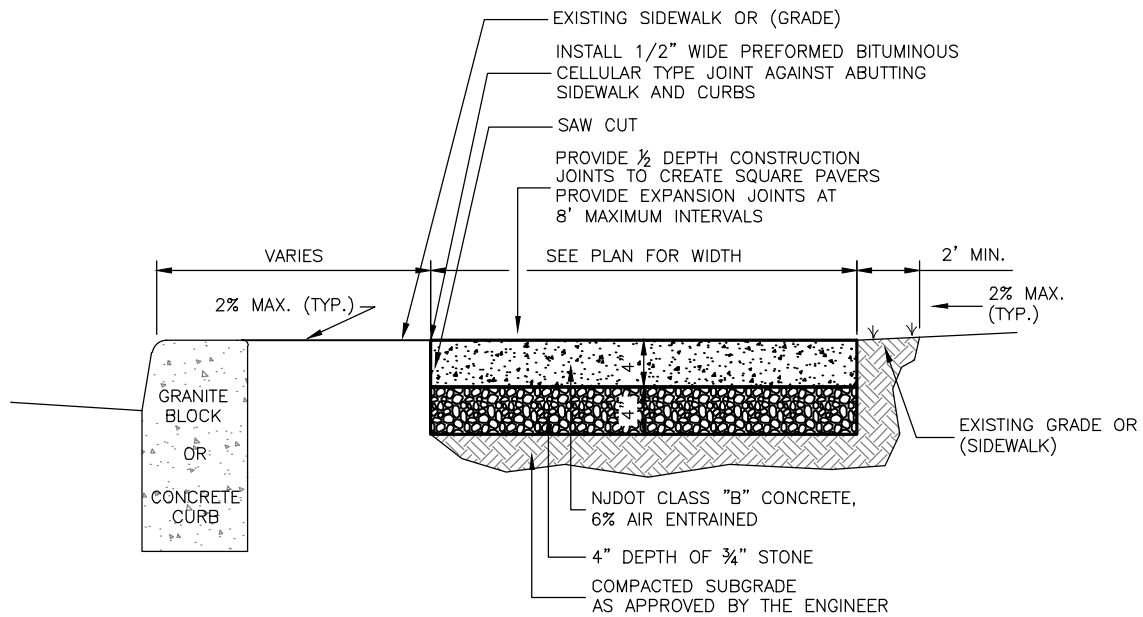

NOTES:

1. EXPANSION JOINTS SHALL BE PREFORMED ASPHALTIC JOINT FILLER COMPLYING WITH THE REQUIREMENTS OF A.A.S.H.T.O. SPEC. M-33. RECESSED 1/4" IN FROM THE SIDEWALK SURFACE
2. CONCRETE SHALL BE AIR ENTRAINED 4500 P.S.I. AT 28 DAY TEST. CONCRETE SHALL BE CURED WITH A COLORLESS CURING COMPOUND, AND FOLLOW ALL GUIDELINES AS SPECIFIED IN NEW JERSEY STATE HIGHWAY STANDARD SPECIFICATIONS, SECTION 903, FOR CONCRETE.

CONCRETE SIDEWALK 4" THICK

N.T.S.

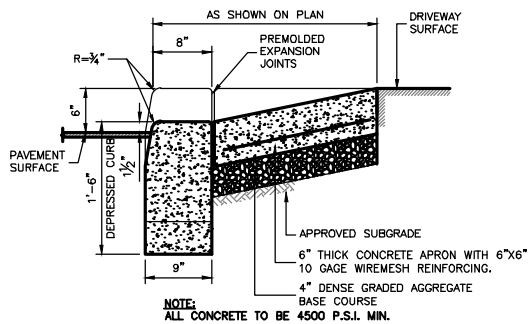
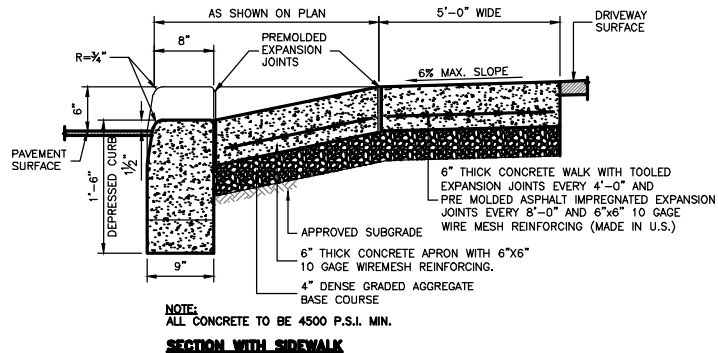
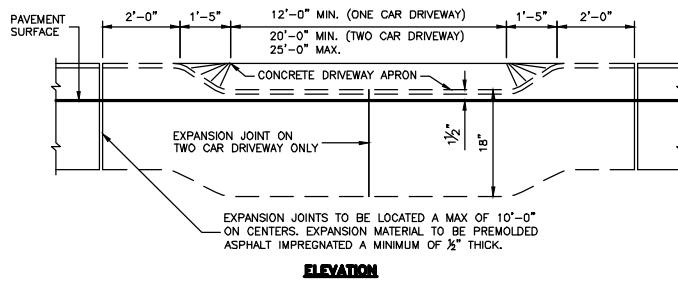
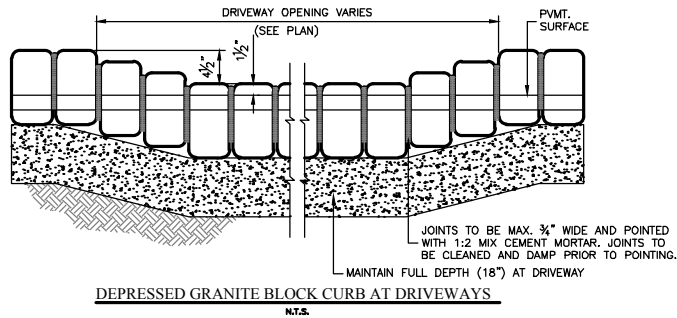

**DEPRESSED CURB, DRIVEWAY ENTRANCE
APRON & SIDEWALK DETAIL**

N.T.S.

NOTES:

1. OPEN JOINTS SHALL BE PROVIDED AT INTERVALS OF 10 FEET AND SHALL BE FILLED WITH 1/2 INCH BITUMINOUS CELLAR COMPRESSION JOINT MATERIAL, RECESSED 1/4 INCH FROM THE FRONT FACE AND TOP OF THE CURB.
2. EXPANSION JOINTS SHALL ALSO BE INSTALLED WHERE THE CURB IS ADJACENT TO SIDEWALKS AND CATCH BASINS.
3. CONCRETE SHALL BE AIR ENTRAINED 4,500 P.S.I. AT 28 DAY TEST. CONCRETE SHALL BE CURED WITH A COLORLESS CURING COMPOUND AS SPECIFIED IN THE NEW JERSEY STATE HIGHWAY STANDARD SPECIFICATIONS, SECTION 903.

Additionally, certain violators may be subject to a claim made by the Commissioner of Insurance in accordance with N.J.S.A. 17:33A-5, the Insurance Fraud Prevention Act.

(1972 Code § 7-13.16)

4-13 RESERVED.

4-14 FIBER OPTIC CABLE.

4-14.1 Findings.

The Township Council finds and determines as follows:

a. The Township frequently receives requests from various business entities engaged in fiber optic and other cable communications industries seeking the Township's approval for the use of rights-of-way, streets, other municipally-owned property and, in some instances, existing easements which previously have been granted by the Township to public utilities for the purpose of installing overhead and/or underground cables, conduits, wires and similar equipment. In the instances involving previously granted easements granted to public utilities, such easements typically were granted many years ago for nominal consideration.

b. Such requests appear to be a part of the Information Super-Highway Network forecast for our Country.

c. Requests of the kind described involve substantial review by the Township Engineer and the Department of Law before approvals can be granted, often involve the excavation of streets, the provision of additional Police services during installation with the concomitant disruption of traffic and public inconvenience and also involve additional time and expense for inspection and expense arising out of potential liability.

d. The Township desires to be supportive of the emerging innovative technology that fiber optic and other cable offers to its users, but not at the expense of burdening Township taxpayers.

e. The imposition of a reasonable annual fee for approvals, licenses, permits or subeasements which are approved and granted will balance the needs of the businesses and of the Township and its taxpayers and promote the public safety and welfare.

(1972 Code § 7-14.1; New)

4-14.2 Application; Fee Schedule.

In order to implement the purposes of this section, the application process and license or permit fee schedule provided hereafter shall apply:

a. Every applicant for the installation of fiber optic or other cable or for the use of a public utility easement shall submit to the Township Director of Community Development: a) a plat showing the proposed location of the fiber optic or proposed installation; b) a depiction indicating whether the proposed installation is overhead or underground; c) copies of all easements proposed to be used which have previously been granted to utilities; and d) all consents for the use of any such easements by the applicable utilities.

b. Every application recommended for approval by the Township Engineer, if approved by the Township Council, shall require as a condition thereof, the following:

1. Payment of a permit fee in accordance with the following schedule:

(a) Above ground installation: fifty (\$0.50) cents per lineal foot; and

(b) Underground installation: seventy-five (\$0.75) cents per lineal foot per year provided that if the installation is located under publicly-owned property (not a right-of-way), the fee shall be one dollar and seventy-five (\$1.75) cents per lineal foot per year.

(c) In no event shall the fee be less than five hundred (\$500.00) dollars.

(d) An engineering and legal professional escrow for review of at least seven hundred fifty (\$750.00) dollars, or more as determined by the Township Director of Community Development.

2. An annual renewal fee payable to the Department of Finance on July 1 of each subsequent fiscal year of \$0.019/linear foot, with minimum of five hundred (\$500.00) dollars.

3. A certificate of insurance naming the Township as an additional insured for general liability coverage in the amount at least five million (\$5,000,000.00) dollars. An applicant may substitute excess umbrella coverage for up to three million (\$3,000,000.00) dollars of the general liability coverage requirement.

4. An indemnification agreement, properly executed by the applicant, which shall hold the Township, its officers, agents and employees harmless from any loss, claim or damage arising out of the installation, maintenance or use of the fiber optic cable installed by the applicant, the form of the agreement to be approved by the Township Attorney;

5. An agreement that the easement holder will permit the Township to use the holder's easement without consideration for the installation of fiber optic or other cable for Township operations, provided that the installation will not interfere with any fiber optic or other cable the easement holders may have previously installed in the easement area. Such agreement shall also provide that any repairs or replacements of Township-owned fiber optic or other cable caused by the holder of a fiber optic permit be performed within twenty-four (24) hours.

6. An agreement that the applicant will provide a minimum of six (6) pairs of strands in each fiber optic cable (i.e., if a cable contains forty-eight (48) strands and two (2) cables are run, the Township will have the use of twelve (12) pairs of strands – six (6) pair per cable) to the Township for its use, and the use of any other governmental and quasi-governmental entities approved by the Township.

c. No license or permit issued hereunder shall be valid for a period of more than the lesser of ten (10) years or, if applicable, the balance of the term of an easement previously granted to a utility pursuant to Title 48 of the New Jersey Statutes.

d. In any instance in which the holder of an existing easement requires that an applicant for license or permit hereunder obtain municipal approval or consent by ordinance, the applicant shall pay to the Township Clerk, in addition to the fee established by paragraph b. above, a fee of one hundred fifty (\$150.00) dollars; and i) the cost of advertising the ordinance prior to adoption; and ii) the cost of advertising the notice of adoption of the ordinance.

e. In the event that the fiber optic or other cable installation interferes with a planned municipal installation, the subject fiber optic or other cable shall be relocated by its owner in an expeditious manner within the right-of-way, to a location approved by the Township at no cost to the Township. The owner of the fiber optic or other cable shall not pay any additional fee to the Township due to the relocation.

f. These procedures shall not be applicable to existing easements previously granted to Public Service Electric and Gas Company (PSE&G), Bell Atlantic–New Jersey (formerly New Jersey Bell Telephone Company) (Bell Atlantic – New Jersey is now known as Verizon) or to existing easements previously granted to or obtained by the present or future holder of a Cable Television franchise granted by the Township.

g. Any underground installation of fiber optic cable, where applicable, shall be required to comply with the street opening requirements set forth in Chapter XXXI, Streets and Sidewalks of the Code to the satisfaction of the Township Director of Community Development.

(1972 Code § 7-14; Ord. No. 04-48; Ord. No. 08-08; New)

ORDINANCE NO. 12-11

**ORDINANCE AMENDING CHAPTER VII, FIBER OPTIC CABLE, SECTION 14.2,
APPLICATION; FEE SCHEDULE OF THE CODE OF THE TOWNSHIP OF
PISCATAWAY**

BE IT ORDAINED by the Township Council of the Township of Piscataway, County of Middlesex, State of New Jersey that Chapter VII, Fiber Optic Cable, Section 14.2, Application; Fee Schedule, of the Revised General Ordinances of the Township of Piscataway, is hereby amended with the additions shown in underline and deletions shown in brackets as follows:

CHAPTER 7-14 FIBER OPTIC CABLE

* * *

7-14.2 Application; Fee Schedule. In order to implement the purposes of this section, the application process and license or permit fee scheduled provided hereafter shall apply:

* * *

b. Every application recommended for approval by the township director of community development, if approved by the council, will require as a condition thereof, the following:

1. Payment of a permit fee in accordance with the following schedule:

* * *

(e). Nothing in this ordinance shall be construed to allow an applicant who is granted a permit by the Township under the provisions of this Code to assign its right to any other entity for purposes of subletting space in the conduit which said applicant has installed or for any other purpose without the express written approval of the Township Council. This provision shall apply to all fiber optic technologies, cable communications and any other emerging technologies used for similar purposes.

(d). An engineering and legal professional escrow for review of at least seven hundred fifty (\$750.00) dollars, or more as determined by the [t]Township [d]Director of [c]Community [d]Development, including a resubmission fee of \$ 250.00 as determined by the Director of Community Development.

This Ordinance shall take effect in the manner provided by law.

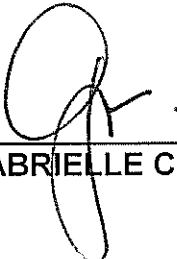

GABRIELLE CAHILL, Council President

Attest:

MELISSA A. SEADER, Township Clerk

Adopted, First Reading: May 15, 2012
Publication Date: May 19, 2012

Adopted, Second Reading: June 7, 2012
Publication Date: June 11, 2012



BRIAN C. WAHLER, Mayor

Date: 6-13-12

CERTIFIED AS TO FORM AND LEGALITY:



MICHAEL J. BAKER, ESQ., Director of Law

STATEMENT OF PURPOSE

The purpose and intent of this Ordinance is to amend the fiber optic ordinance to require prior written approval of Township Council for license holder to assign license rights to third parties and to allow a resubmission review fee.